

ESCALERES BARRANES

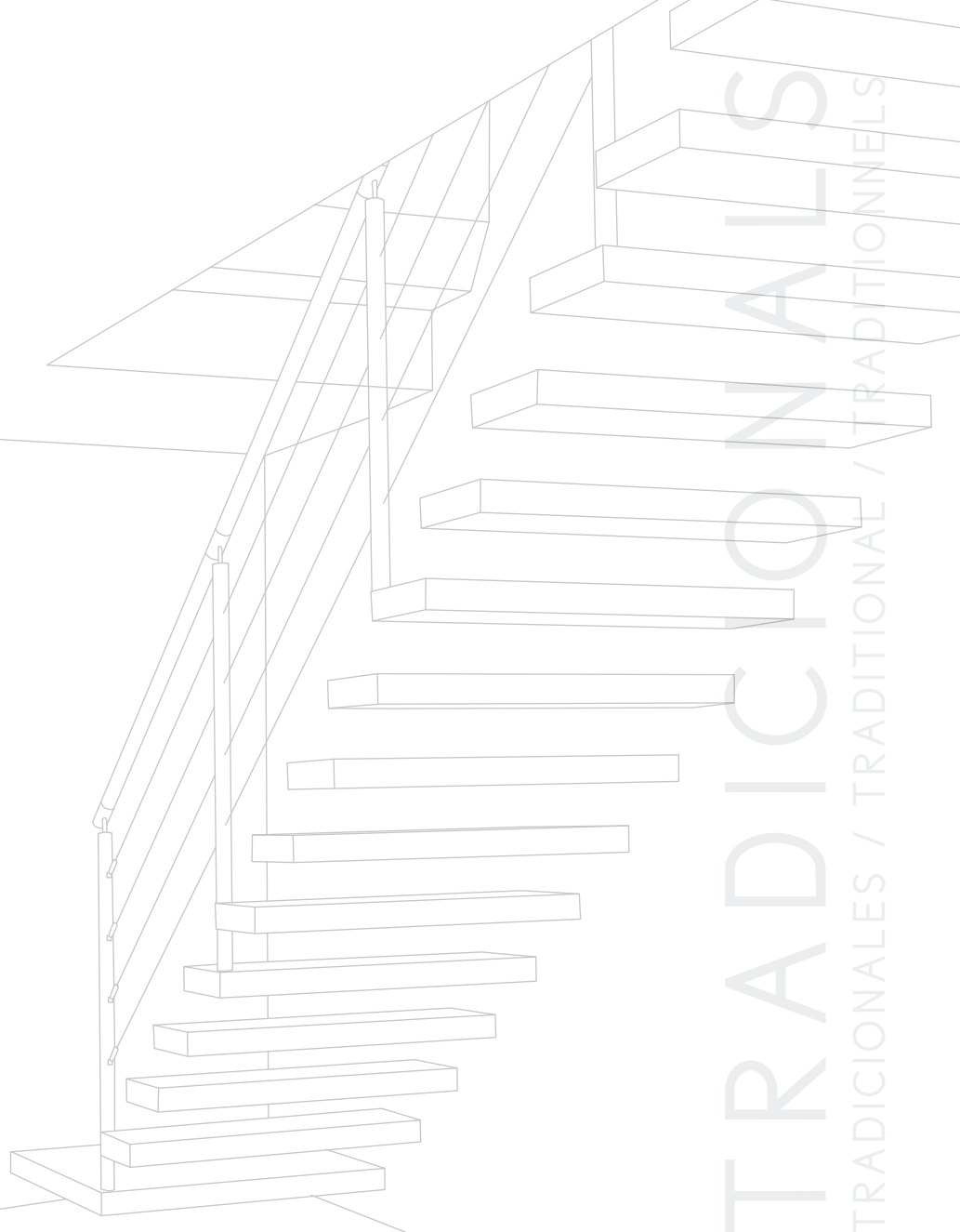



TRADICIONALS
TRADICIONALES / TRADITIONAL / TRADITIONNELS



TRADITIONALS

TRADICIONALES / TRADITIONAL / TRADITIONNELS



Dissenyem unions funcionals, adaptables i decoratives. Escalles a mida elaborades i muntades per personal especialitzat.



Diseñamos uniones funcionales, adaptables y decorativas. Escaleras a medida elaboradas y montadas para personal especializado.

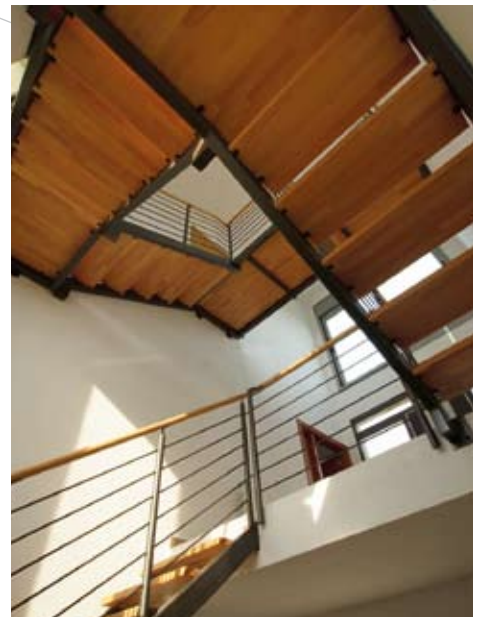

We design functional linking systems that are adaptable and decorative. Made-to-measure stairs produced and fitted by specialists.

Nous concevons des assemblages fonctionnels, adaptables et décoratifs. Escaliers sur mesure, fabriqués et montés par du personnel spécialisé.

Aprofitem la superfície per crear l'equilibri entre disseny i comoditat.
Estètica d'helicoide en espais circulars o quadrats.

Aprovechamos la superficie para crear el equilibrio entre diseño y comodidad.
Estética de helicoide en espacios circulares o cuadrados.

We make the best of the space available to achieve a balance between design and comfort.
A helical look for circular or square spaces.

Nous tirons partie de l'espace pour créer un équilibre entre design et commodité.
Esthétique hélicoïdale dans des espaces circulaires ou carrés.



CARGOL

CARACOL / SPIRAL STAIRCASES / COLIMAÇON

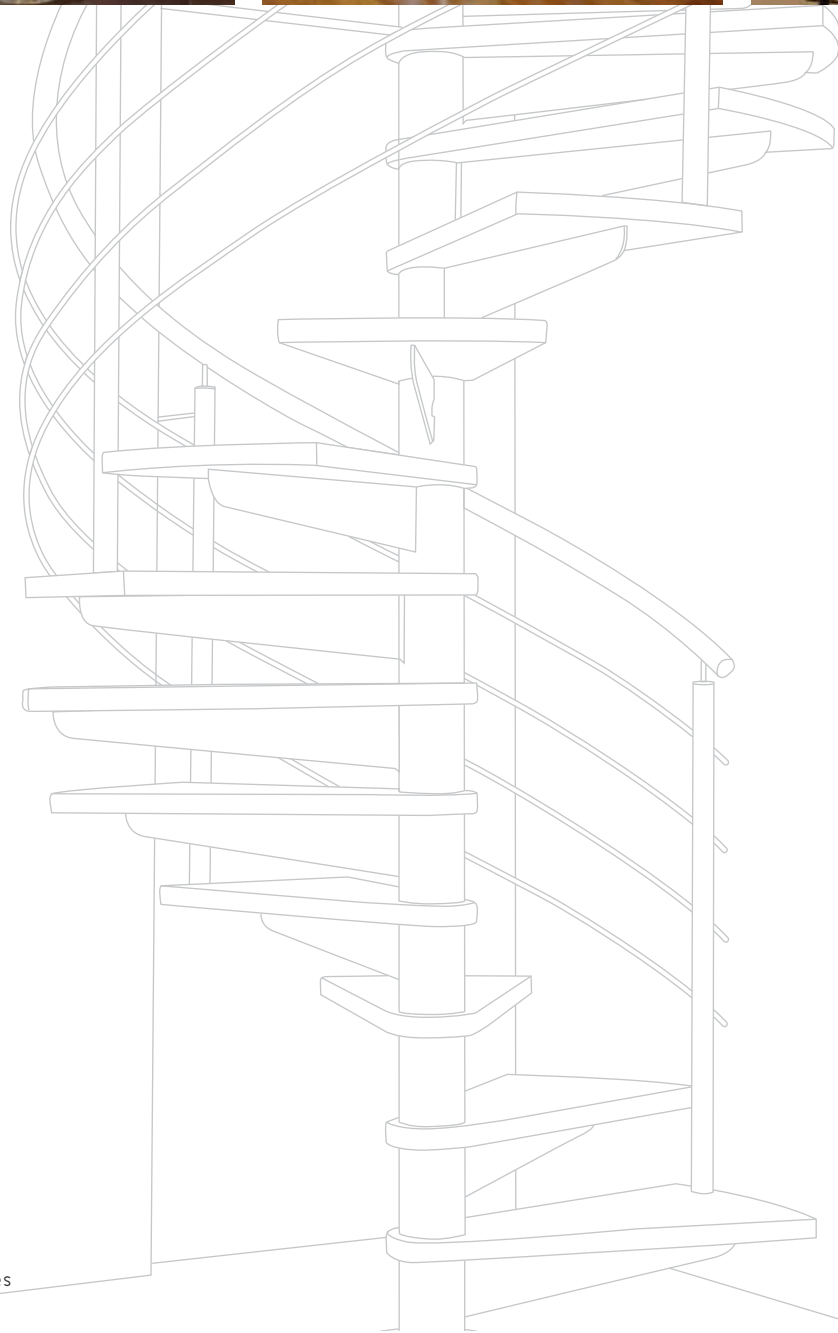

CARACOL / SPIRAL STAIRCASES / COLIMAÇON

CARGOL



ESPACIOS REDUCIDOS / SMALL SPACES / ESPACES RÉDUITS

ESPACIS REDUITS



Enllacem ambients prioritant l'ús de l'espai.
Escalaes modernes que aposten pel disseny i la tecnologia.

Enlazamos ambientes priorizando el uso del espacio.
Escaleras modernas que apuestan por el diseño y la tecnología.

We link up different ambiances giving priority to space utilisation.
Modern stairs committed to design and technology.

Nous reions différentes ambiances en donnant la priorité à l'utilisation de l'espace.
Des escaliers modernes qui misent sur le design et la technologie.

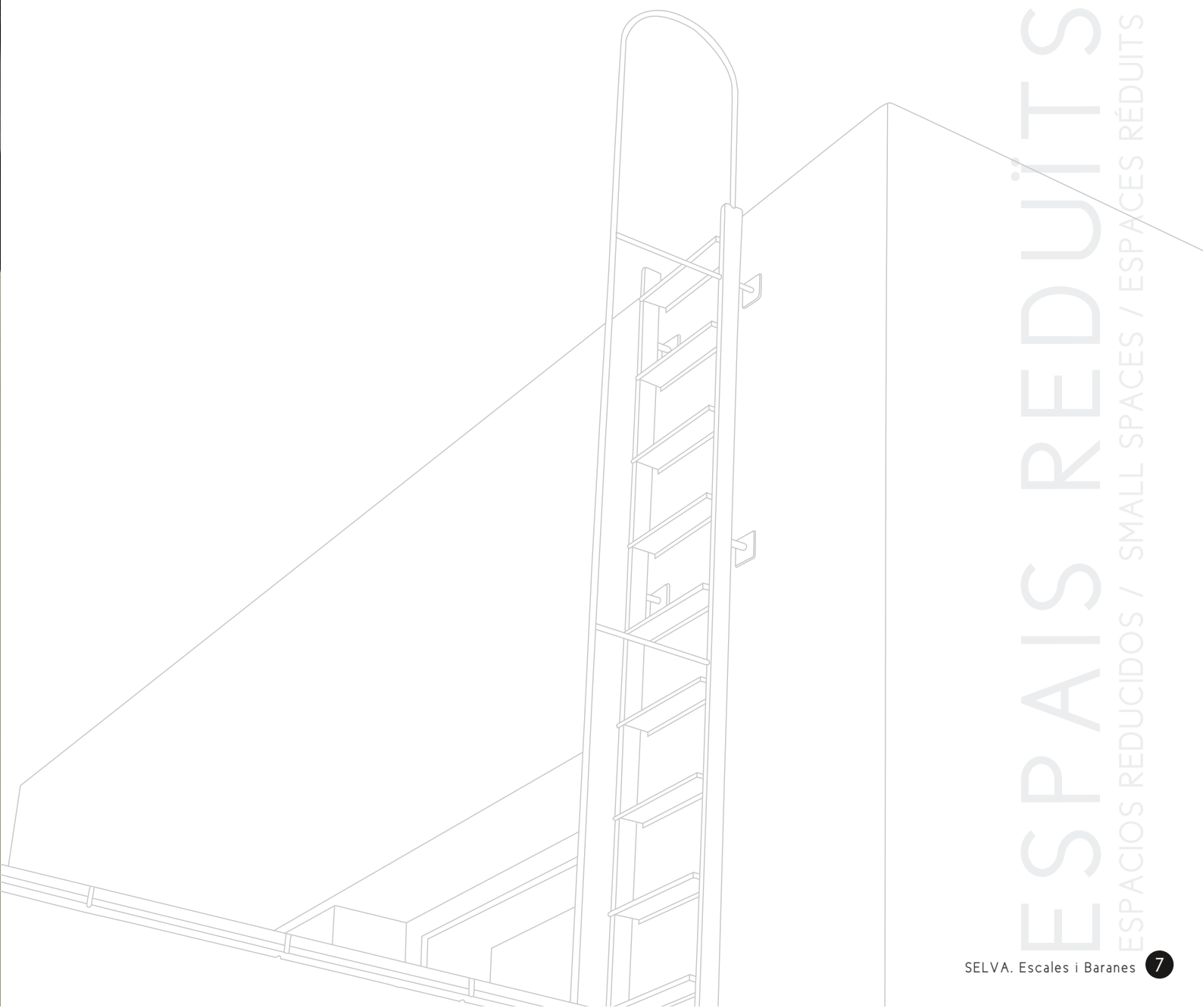

ESPAIS REDUITS
ESPACIOS REDUCIDOS / SMALL SPACES / ESPACES RÉDUITS

REVESTIMENTS

REVESTIMENTOS / CLADDINGS / REVÊTEMENTS



Aconsegüim adornar i donar més fermesa a les construccions que han quedat obsoletes. Materials resistents i respectuosos amb el medi ambient.

Conseguimos adornar y dar más firmeza a las construcciones que han quedado obsoletas. Materiales resistentes y respetuosos con el medio ambiente.

We succeed in adorning and reinforcing constructions that have become obsolete. Strong, environment-friendly materials.

Nos revêtements permettent de décorer et de rendre plus solides les constructions devenues obsolètes. Matériaux résistants qui respectent l'environnement.



REVESTIMENTS

REVESTIMIENTOS / CLADDINGS / REVÊTEMENTS



BARANES
BARANDILLAS / HANDRAILS / MAINS COURANTES

BARANES

BARANDILLAS / HANDRAILS / MAINS COURANTES

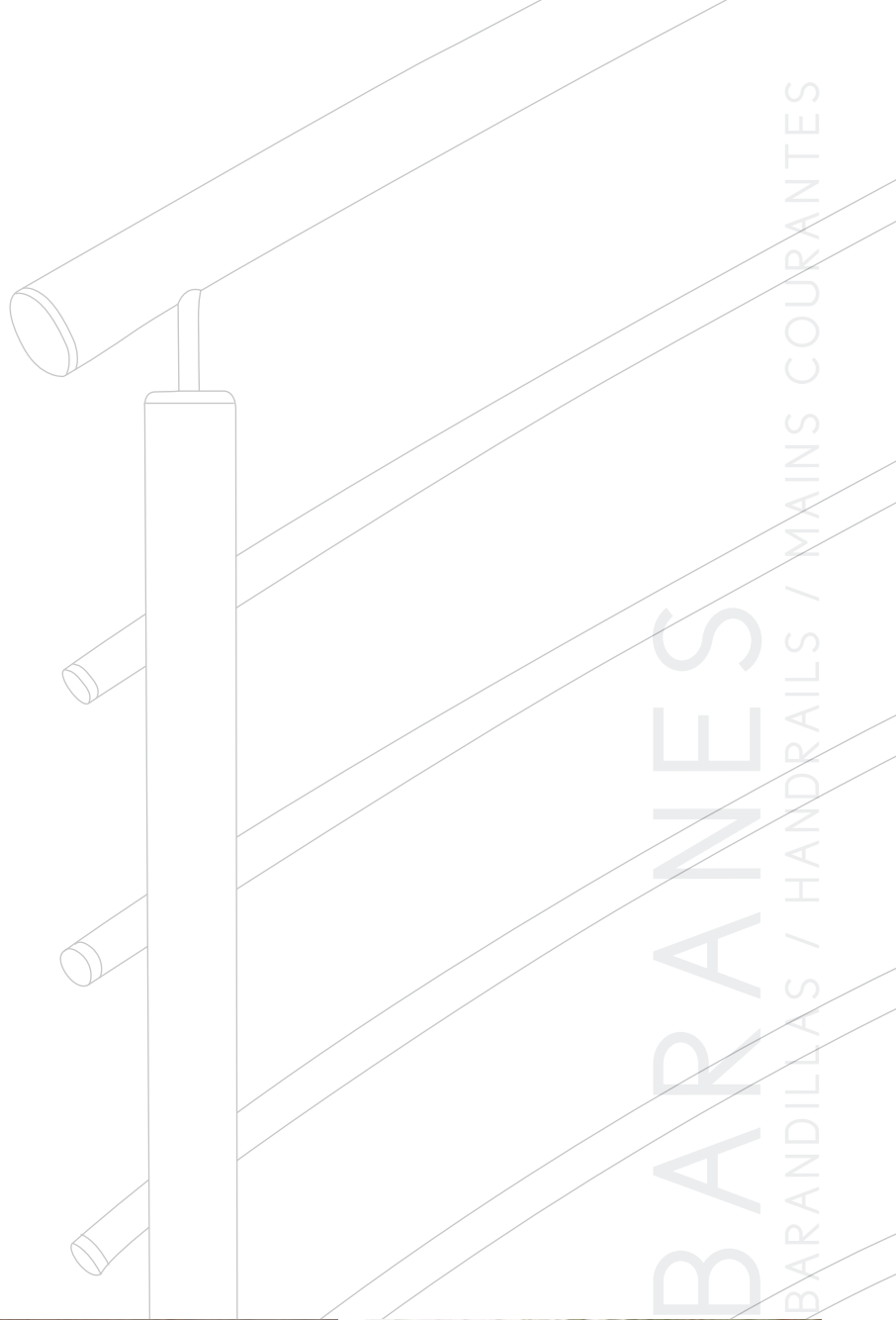

Creem proteccions tècniques equipant edificis.
Per escales lleugeres o de formigó.

Creamos protecciones técnicas equipando edificios.
Para escaleras ligeras o de hormigón.

We create engineering-grade protection systems for fitting to buildings.
For light or concrete staircases.

Nous créons des protections techniques pour équiper les immeubles.
Pour escaliers légers ou en béton.

PLEGABLES

FOLDING STAIRS / PLIABLES

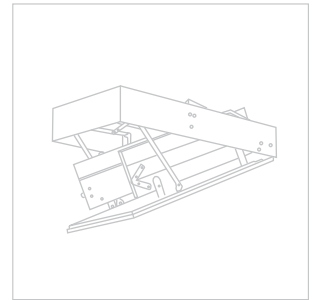
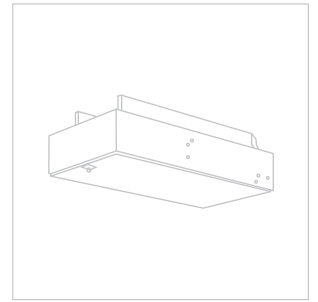
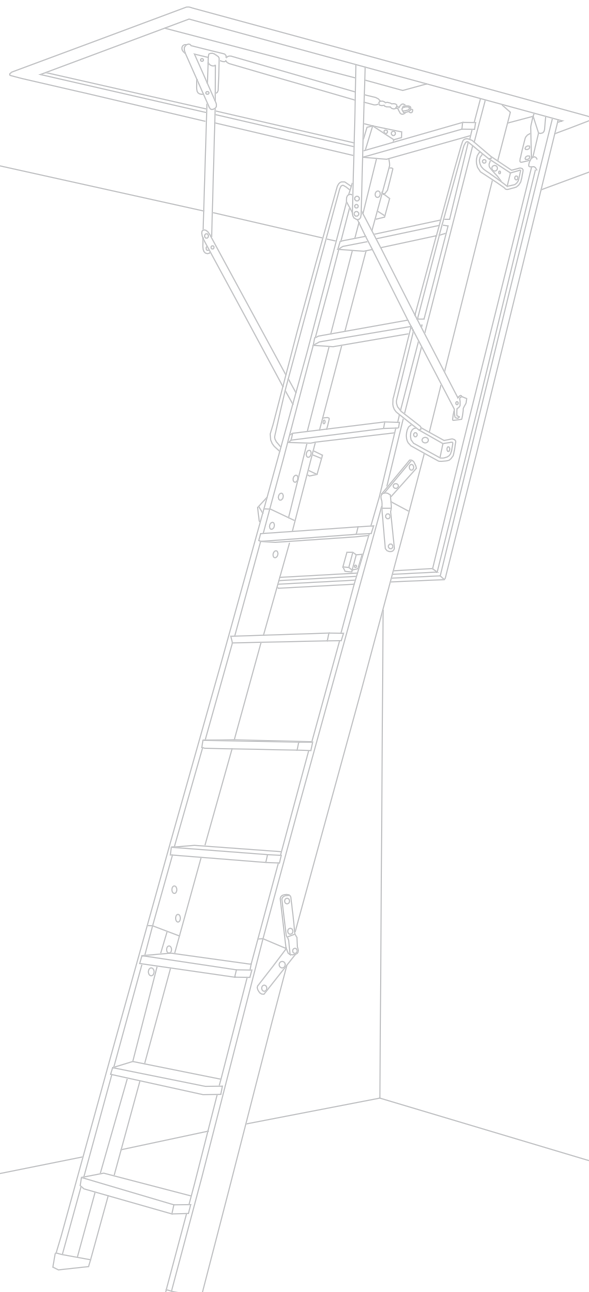

PLEGABLES

FOLDING STAIRS / PLIABLES

Fem invisible l'accés a zones secundàries. Aprofitament de la sota coberta.

Hacemos invisible el acceso a zonas secundarias. Aprovechamiento de la bajo cubierta.

We make access points to secondary zones invisible. For making use of spaces under the ceiling.

Nous rendons invisible l'accès à des zones secondaires. Exploitation des combles.



Tota l'experiència dedicada a la millora diària en fabricació, instal·lació i acabats. Treballs amb tecnologia Autocad, precisos i de qualitat.

Toda la experiencia dedicada a la mejora diaria en fabricación, instalación y acabados. Trabajos con tecnología Autocad, precisos y de calidad.

A great store of experience in the service of constant improvements to the manufacturing, fitting and finishing of the products. Projects carried out with Autocad technology, giving precision and high quality.

Nous consacrons toute notre expérience à l'amélioration quotidienne de la fabrication, de l'installation et des finitions. Travaux précis et de qualité grâce à la technologie Autocad.

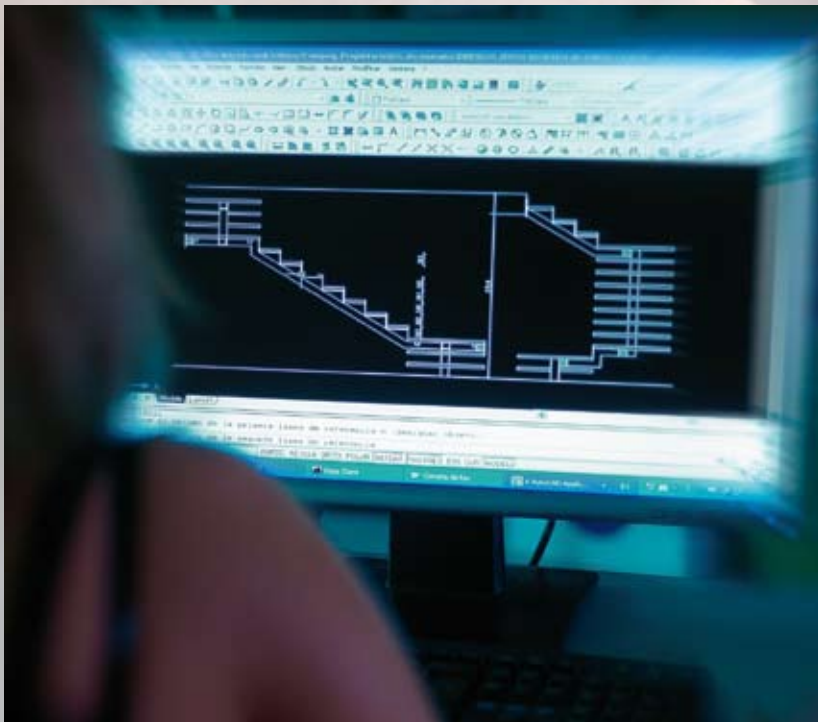

ESCALERES i BARANES

ESCALERAS y BARANDILLAS / STAIRS and HANDRAILS / ESCALIERS et MAINS COURANTES

